

## Corded Robotic Pool Cleaner

Model: ERA™ 710

TYPE EP37--

### **WARNING**

**FOR YOUR SAFETY** – For anything other than the routine cleaning and maintenance described in this owner's manual, this product must be serviced by a qualified professional with sufficient experience in pool equipment installation and maintenance so that all of the instructions in the product's complete owner's manual can be followed exactly. All safety instructions must be followed explicitly in order to prevent injury hazards. Never turn the cleaner on unless it is fully submerged in the water. Improper installation and/or operation may void the warranty. The owner/operator of this equipment should keep this document.

 **BEFORE YOU START** – This Owner's Manual contains essential operation and start-up instructions. Read complete manuals and all safety warnings accompanying this system before commencing operation or start-up. Visit [polarispool.com](http://polarispool.com) or call (800) 822-7933 for additional copies of all instructions.

# Table of Contents

<b>Section 1. Cleaner Specifications and Overview</b> .....	<b>3</b>	<b>Section 3. Storage Guidelines</b> .....	<b>5</b>
1.1 Technical Specifications .....	3	<b>Section 4. Maintenance</b> .....	<b>5</b>
1.2 Product Overview and Contents.....	3	4.1 Replacing the Cleaner .....	5
1.3 Usage Guidelines.....	3	4.2 Cord Tangling.....	5
<b>Section 2. Product Usage</b> .....	<b>3</b>	4.3 Cleaning the Filter Canister .....	6
2.1 Connect the Control Box .....	3	4.4 Cleaning the Impeller Area.....	7
2.2 Install and Submerge the Cleaner .....	4	4.5 Replacing the Brushes.....	7
2.3 Control Box Functions .....	4	4.6 Replacing the Tracks .....	8
2.4 Start / Stop Cleaning .....	4	<b>Section 5. Troubleshooting</b> .....	<b>9</b>
2.5 Manual Pool Removal.....	4	5.1. Using the Information LED.....	9
		5.2. General Troubleshooting.....	10

THANK YOU FOR PURCHASING THIS POLARIS CLEANER.

YOUR POLARIS ROBOTIC CLEANER HAS BEEN DESIGNED AND MANUFACTURED TO BE EASILY INSTALLED AND TO PROVIDE LOW MAINTENANCE OPERATION. PRIOR TO INSTALLING, PLEASE DO THE FOLLOWING:

- 1) Complete the warranty registration card.
- 2) Record your purchase information below.
- 3) Attach your invoice (or a copy) to this page.

Taking these steps will help ensure prompt warranty service, should it be required. If service is required, please contact your original dealer. If the original dealer does not perform warranty service, please visit [polarispool.com](http://polarispool.com) to locate an independent service company near you. If you are unable to locate a service company, please call our Technical Support department at 1.800.822.7933.

Date of Purchase \_\_\_\_\_ Purchased From \_\_\_\_\_ Serial Number \_\_\_\_\_  
 (located on robot head)

City \_\_\_\_\_ State/Province \_\_\_\_\_ Zip/Postal Code \_\_\_\_\_

SCAN TO REGISTER YOUR PRODUCT:



## Section 1. Cleaner Specifications and Overview

### 1.1 Technical Specifications

	ERA™ 710
Control Box Power Supply	100 – 240 VAC, 50/60Hz. Class II*
Cleaner Power Supply Voltage	30 VDC
Maximum Power Input	100 W
Floating Cable Length	54 ft (16.5 m)
Cleaner Size (L x W x H)	14.5 x 11.4 x 11.8 in (37 x 29 x 30 cm)
Cleaner Weight	12 lbs. (5.5 kg)
Packed Weight	22 lbs. (10.1 kg)
Water Temperature Range	Min: 55°F (13°C) Max: 95°F (35°C)
Operating Depth Range	Min: 15 in (40 cm) Max: 13 ft (4 m)
Control Box Rating	IP45
Cleaner Rating	IPX8

\*Class II: appliance with double insulation or reinforced insulation that does not require grounding.

### 1.2 Product Overview and Contents

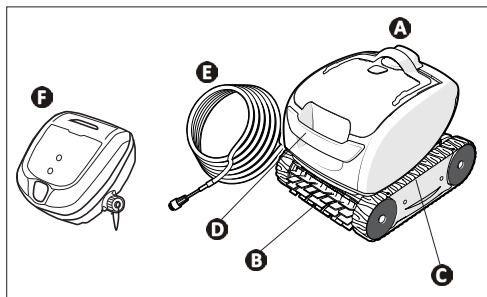

- A. Lid Handle and Filter Access
- B. Brush
- C. Tracks
- D. Handle
- E. Floating Cable
- F. Control Box

### 1.3 Usage Guidelines

- DO NOT USE AN EXTENSION CORD TO CONNECT THE UNIT TO ELECTRIC SUPPLY; PROVIDE A PROPERLY LOCATED GFCI RECEPTACLE. THE CONTROL BOX SHOULD BE PLUGGED INTO THE GFCI RECEPTACLE BOX
- The cleaner must be installed and operated as specified. See safety and warning manual for more information.

- This product is intended for use with permanently-installed pools. Do not use with storable pools. A permanently-installed pool is constructed in or on the ground or in a building such that it cannot be readily disassembled for storage. A storable pool is constructed so that it is capable of being readily disassembled for storage and reassembled to its original integrity.
- Clean the filter canister after each use.
- Do not use the product in your pool if the water temperature is above 95°F (35°C) or below 55°F (13°C).
- Certain vinyl liner patterns are particularly susceptible to rapid surface wear or pattern removal caused by objects coming into contact with the vinyl surface, including pool brushes, pool toys, floats, fountains, chlorine dispensers, and automatic pool cleaners. Some vinyl liner patterns can be seriously scratched or abraded simply by rubbing the surface with a pool brush. Ink from the pattern can also rub off during the installation process or when it comes into contact with objects in the pool. Fluidra is not responsible for, and the Limited Warranty does not cover, pattern removal, abrasion or markings on vinyl liners.

## Section 2. Product Usage

### 2.1 Connect the Control Box

#### ⚠ WARNING

Failure to comply with the following warnings can result in permanent injury, electrocution or drowning.

#### PREVENT ELECTRICAL SHOCK AND FIRE

- **U.S.:** Per NEC® requirements, keep the control box at least five (5) ft. (1.5 m) from the edge of the pool.
- **CANADA:** Per CEC requirements, keep the control box at least three (3) m (10 ft.) from the edge of the pool.
- Only connect the control box to a receptacle protected by a ground fault circuit interrupter (GFCI). Contact a certified electrician if you cannot verify that the receptacle is protected by a GFCI.
- Do not use an extension cord to connect the control box.

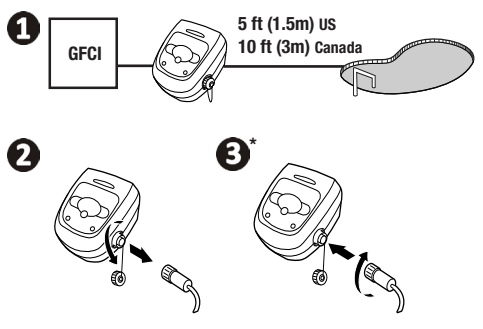

- \* Connector is keyed; do not force. Securely screw the connector to avoid water exposure.

## 2.2 Install and Submerge the Cleaner

- Prepare the cable by unrolling to prevent tangles (see **1**).
- Position yourself halfway along the length of the pool before submerging the cleaner (see **2**). This will optimize the cleaner's movement and reduce cable tangling.
- Place the cleaner vertically into the water (see **3**). Shake it slightly to release air bubbles.
- Allow it to sink to the bottom of the pool. Place only enough cable in the water to reach the farthest end of the pool (see **4**).

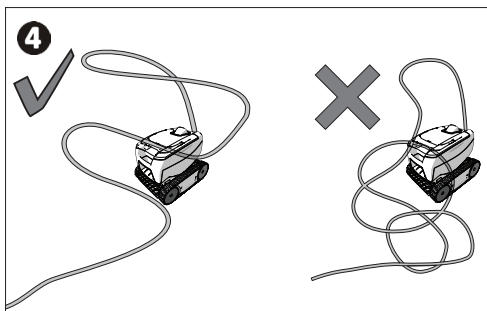
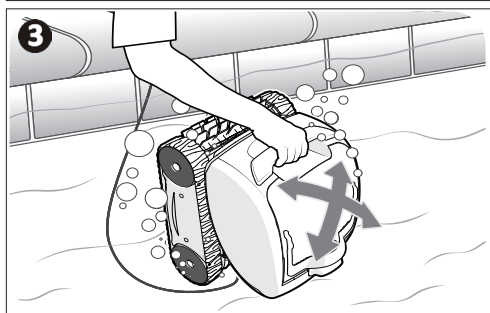
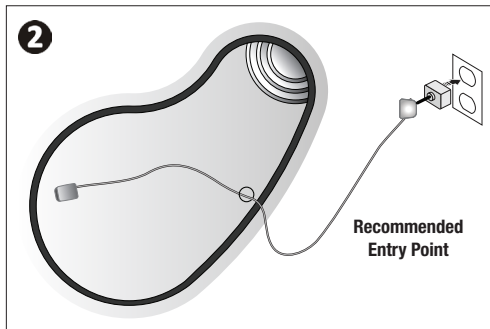
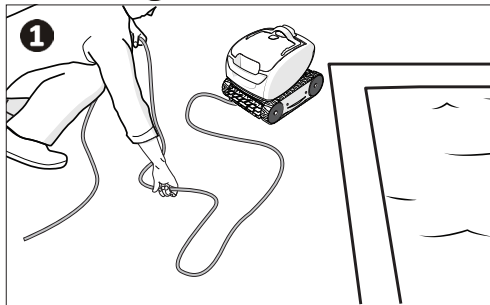

## 2.3 Control Box Functions

Symbol	Description	ERA 710
	Start / Stop cleaner	<input checked="" type="checkbox"/>
	Information LED	<input checked="" type="checkbox"/>
	Floor and Wall Mode	Preset

## 2.4 Start / Stop Cleaning

- With cleaner submerged in water, press to begin operation. Press again to interrupt and cancel an in-progress cleaning cycle.

**NOTE:** During the cleaning cycle, the cleaner is designed to periodically lift or tip up as it rotates.

**NOTE:** The robotic cleaner has a safety feature that stops it if a cleaning cycle starts without being submerged. For pools with a beach or shallow area, it will try to reverse and return to the pool when the impeller is out of the water.

## 2.5 Manual Pool Removal

- When cleaning cycle ends, always remove the cleaner from the pool.
- Gently pull the floating cable to bring the cleaner within arm's reach.
- Use the handle to lift the cleaner out of the water. Never lift the cleaner out of the pool by the floating cable (see **1**).
- Hold the cleaner vertically over the pool surface to drain water before removing.

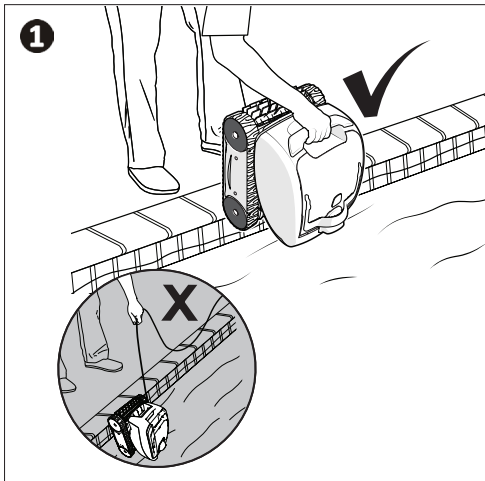

### Section 3. Storage Guidelines

Store the cleaner in a protected and dry area out of reach of children, pets, etc.

- Disconnect cleaner from the power source.
- Disconnect the floating cable from the control box.
- Starting at the cleaner head, untangle all kinks and coils in the floating cable. Lay the cable in the sun to loosen any tangling memory.
- Loosely coil the cable into a loop for storage near the cleaner.
- Store at least 11.5 ft (3.5 m) away from the pool edge.
- Keep out of direct sunlight.
- Avoid rain and inclement weather.
- Do not leave the cleaner in the water after prolonged periods when not in use.

### Section 4. Maintenance

#### ⚠ WARNING

Disconnect the product from the power supply to avoid injury.

#### 4.1 Cleaning the Cleaner

- Rinse with clean (non-chlorinated) water and mild soap avoiding harsh solvents.
- Do not let the product dry in the sun

#### 4.2 Cord Tangling

Tangling can occur more frequently when the cleaner is not attended to after each cleaning cycle. Proper installation, general maintenance and the following troubleshooting steps can help to avoid cable challenges.

#### IMPORTANT

Cleaner power cable may become tangled if correct procedure is not followed after each cleaning cycle.

**NOTE:** Place all of the floating cable in the water to allow free movement in your pool from the central point. Spread out the floating cable ensuring there are no kinks or coils in the cable.

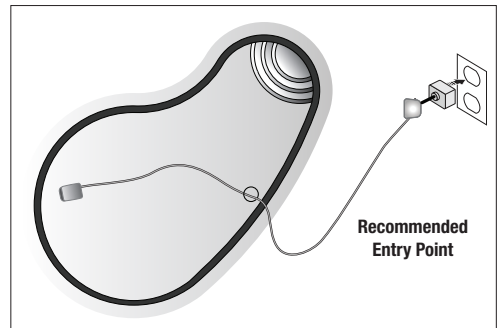

If tangling occurs, follow these steps:

- Remove the cleaner from the pool. When the cleaner is within arm's reach, use the handle to remove from the water. Never lift the cleaner out of the pool by the floating cable (see **1**).
- Hold the cleaner vertically to drain.
- Unplug power to the cleaner at the control box (see **2**).
- Untangle all kinks and coils in the floating cable starting at the cleaner head. Lay the cable in the sun to loosen any tangling memory (see **3**).

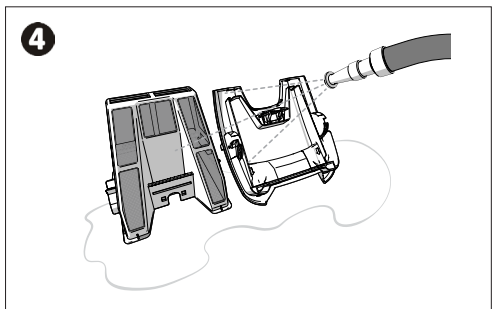
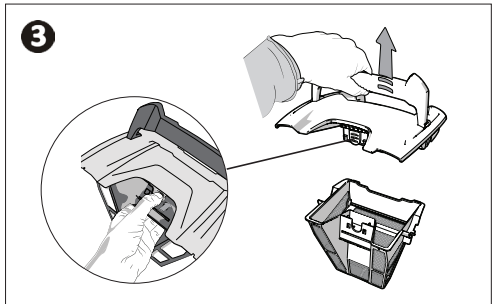
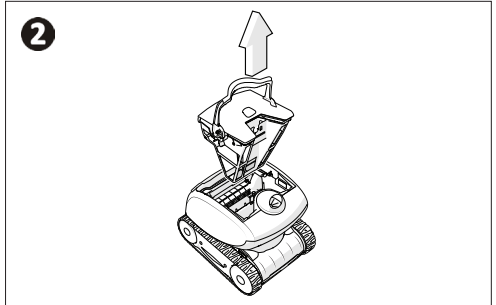
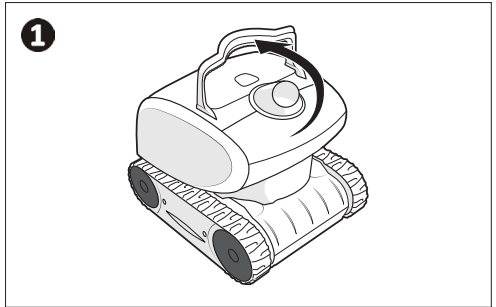
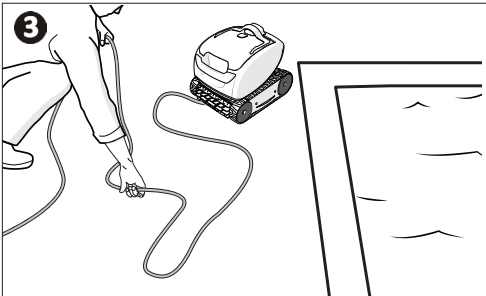
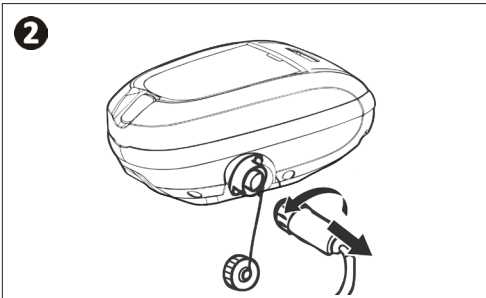
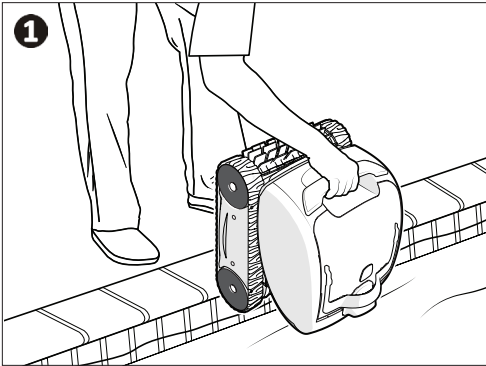

### 4.3 Cleaning the Filter Canister

- The filter canister should be rinsed with clean (non-chlorinated) water at the end of each cycle.
- Periodically, clean the canister with soapy water and a soft bristle brush to remove fine particles that clog the material. Rinse with clean (non-chlorinated) water.

#### 4.4 Cleaning the Impeller Area

### ⚠ WARNING

Disconnect the product from the power supply and wear gloves to avoid injury.

- Remove lid and filter canister (see **1**).
- Remove the external flow guide (see **2**).
- Unscrew the internal flow guide by hand (see **3**).
- Remove the internal flow guide (see **4**).
- Wear protective gloves when touching the impeller (see **5**).
- Carefully remove debris that may be wrapped around and blocking the impeller (see **6**).

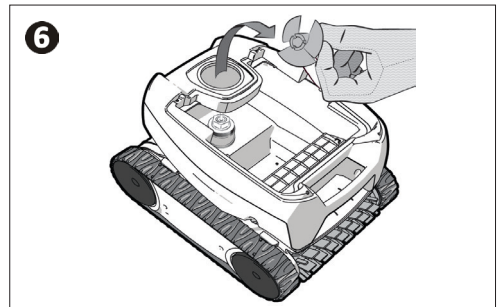
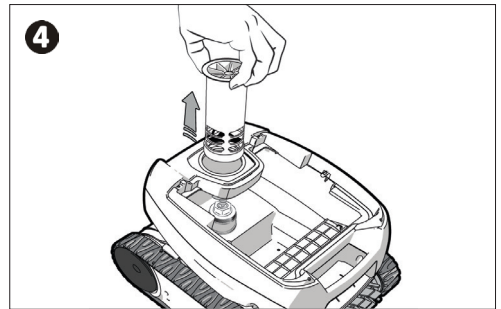
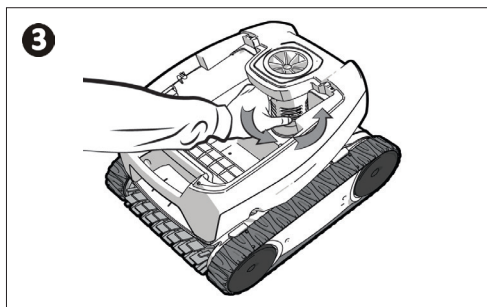
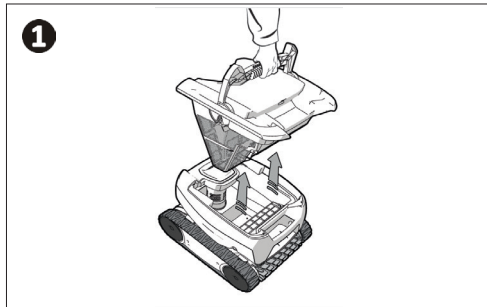

#### 4.5 Replacing the Brushes

- Replace the brushes if wear indicators are as shown:

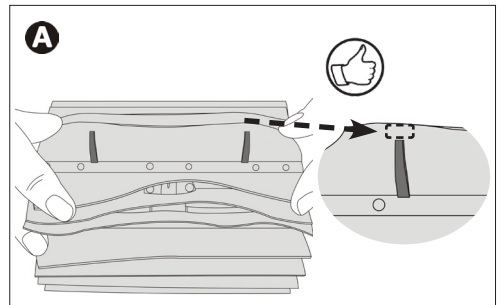

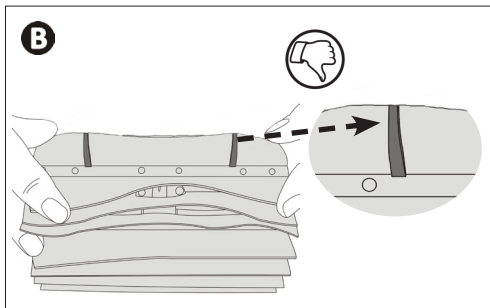

- Remove the brushes by pulling apart the tabs as shown:

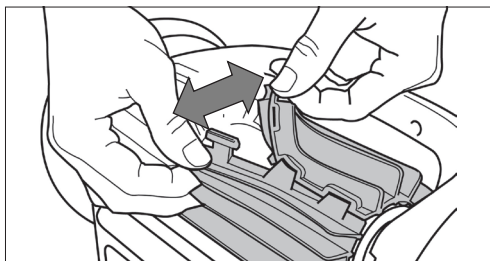

- To replace, position a new brush without tabs under the brush holder (see **1**).
- Roll the brush around the support, slide the tabs into the slits and pull until the wide edge passes through each slit (see **2**).
- Cut the tabs with scissors to be level with the other blades (see **3**).

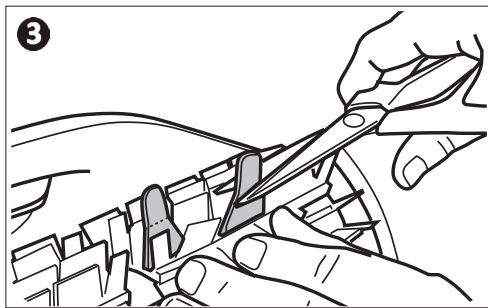
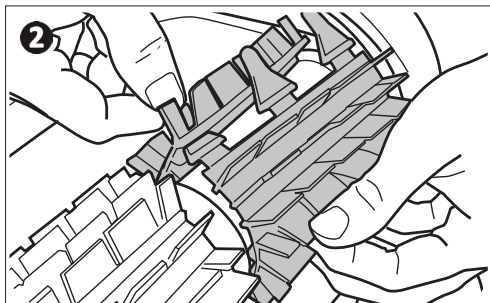
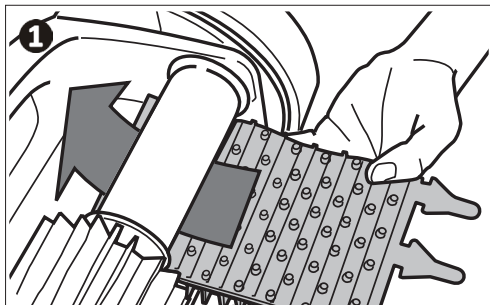

#### 4.6 Replacing the Tracks

- Replace the tracks if the wear indicator is worn, the treads are smooth, or the tracks are loose.
- Stand cleaner on its side and pull the old track over the wheel to remove (see **1**).
- Replace the tracks by positioning the inside rib of the track into the groove of the first wheel. Stretch the track around the second wheel, push down and position the rib of the track so that it's seated properly in the groove of the wheel (see **2**).
- Verify the rib of the track is positioned properly within the groove of each wheel. If necessary, turn the wheels gently to seat track.

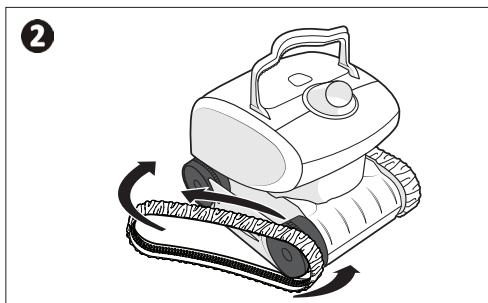
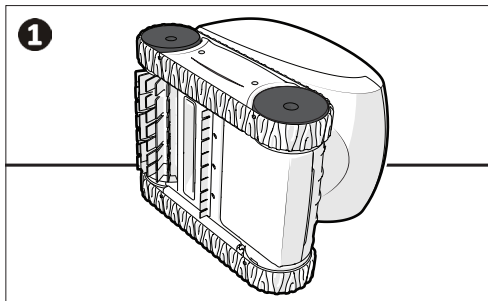

## Section 5. Troubleshooting

### 5.1. Using the Information LED

The Information LED  on the control unit flashes in a specific sequence to indicate one of three possible cleaner malfunctions.

LED Flashing	Solution
<p><b>Single Flash</b> LED flashes once with one second interval</p>	<ul style="list-style-type: none"> <li>• Unplug the floating cable from the control unit and reconnect.</li> <li>• If the problem persists, contact your local retailer to request a diagnostic review or contact Technical Support at 1-800-822-7933.</li> </ul>
<p><b>Two Flashes</b> LED flashes twice with one second interval</p>	<ul style="list-style-type: none"> <li>• Turn cleaner wheels to ensure they are not jammed.</li> <li>• Check brushes for debris.</li> <li>• Start a new cleaning cycle.</li> <li>• If the problem persists, contact your local retailer to request a diagnostic review or contact Technical Support at 1-800-822-7933.</li> </ul>
<p><b>Three Flashes</b> LED flashes three times with one second interval</p>	<ul style="list-style-type: none"> <li>• Clean the filter canister.</li> <li>• Check the pump axle for debris.</li> <li>• Check propeller for debris.</li> <li>• Start a new cleaning cycle.</li> <li>• If the problem persists, contact your local retailer to request a diagnostic review or WITH contact Technical Support at 1-800-822-7933.</li> </ul>

## 5.2. General Troubleshooting

The following list provides some helpful hints for troubleshooting common challenges when using the cleaner.

Problem	Cause	Solution
The Information LED flashes just after start (either pressing Power or Cycle button for less than 20 seconds).	Floating cable may not be plugged into the control unit correctly.	Unplug floating cable from the control unit and reconnect.
	Cleaner may not be fully submerged.	Remove cleaner from the pool and re-submerge.
	Propeller may be jammed and not turning correctly.	Clean the filter canister.
	Wheels may be jammed and not turning correctly.	Turn the tracks then disconnect the control unit and wait at least 20 seconds before reconnecting. If the problem persists, contact your local retailer to request a diagnostic review or contact Technical Support at 1-800-822-7933.
The Information LED flashes during the cleaning cycle.	Cleaner may be sucking air (lights will appear after 60 seconds air intake).	Remove cleaner from the pool and re-submerge.
The cleaner does not stay firmly on the pool bottom.	There is air in the cleaner.	Remove cleaner from pool and re-submerge.
	The filter canister is full or dirty.	Clean the filter canister.
The cleaner does not or no longer climbs the pool walls.	The filter canister is full or dirty.	Clean the filter canister.
	Walls of pool are slippery. Although the water seems clear, microscopic algae, invisible to the human eye, may be present in the pool. As a result the pool sides become slippery and prevent the cleaner from climbing. Check tracks for wear and replace as necessary.	Do a shock chlorination treatment to reduce the pH levels in the pool. DO NOT leave the cleaner in the pool during this treatment.
On startup the cleaner does not move.	No power supply to the cleaner.	Check that the outlet to which the control unit is connected is receiving electricity.
	Unit is turned OFF.	Press Start/Stop again. If the problem persists, contact your local retailer to request a diagnostic review or call Technical Support.
Cable is tangling in the pool.	Cable is not spread evenly in the water.	Verify the floating cable enters the water near the middle of the pool length. Spread all of the floating cable carefully in the pool, ensuring there are no kinks or coils.
The cleaner is not cleaning effectively.	The brushes have become smooth or the "wear" indicator shows.	Replace the brushes.
	Filter canister is full or dirty.	Clean the filter canister.
	Floating cable is excessively coiled or kinked.	Make sure the floating cable is spread out over the pool. Ensure the cable is not too tightly wrapped or coiled when storing. If the problem persists, lay the cable straight in the sun to relax it and remove kinks.
	Track is coming off the wheels.	Verify track is properly inserted in the wheel groove. If problem persists, replace the tire track.



**A Fluidra Brand** | PolarisPool.com | PolarisPool.ca  
2882 Whiptail Loop # 100, Carlsbad, CA 92010, USA | 1.800.822.7933  
2-3365 Mainway, Burlington, ON L7M 1A6, Canada | 1.800.822.7933

©2025 Fluidra. All rights reserved. All trademarks are property of their respective owners. App Store is a service mark of Apple, Inc., registered in the U.S. and other countries. Google Play and the Google Play logo are trademarks of Google LLC.

H0907100\_REVB